

INSTRUCTIONS

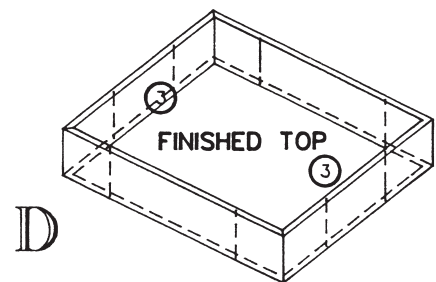

BOX

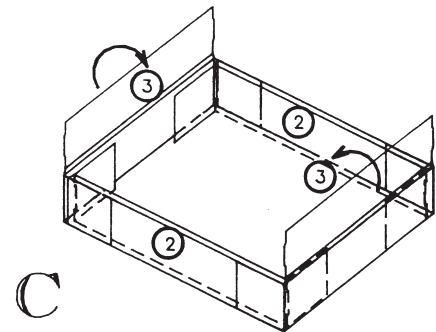
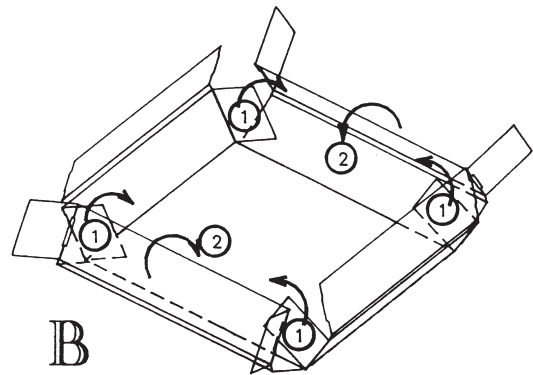
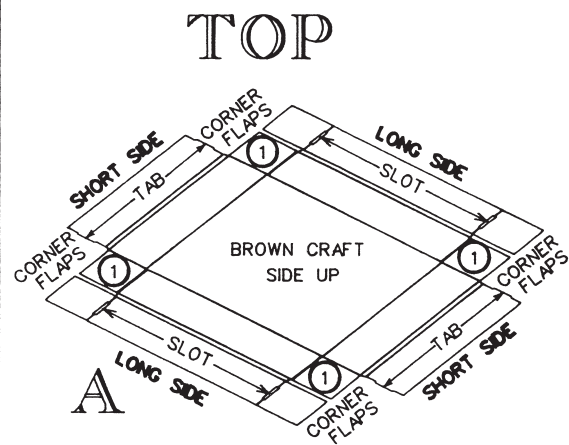
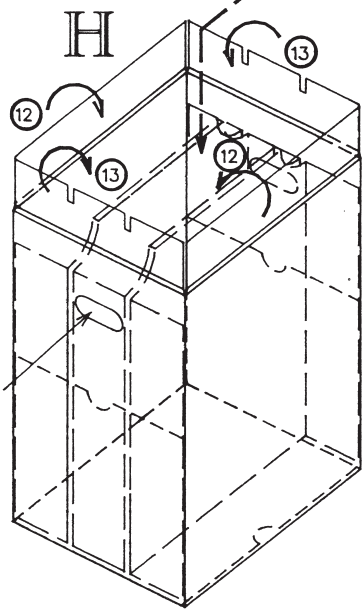
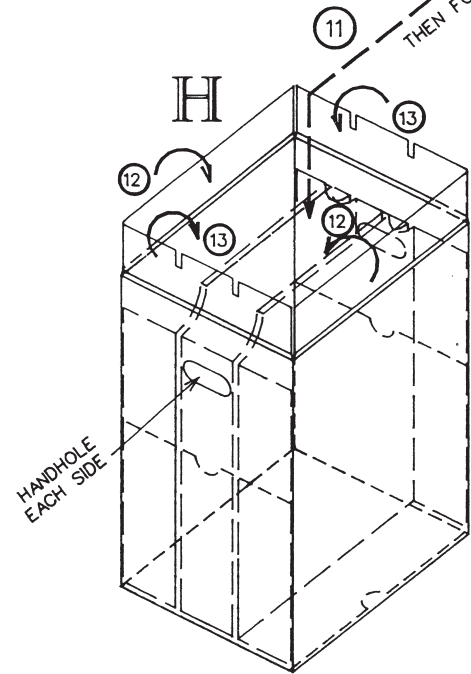
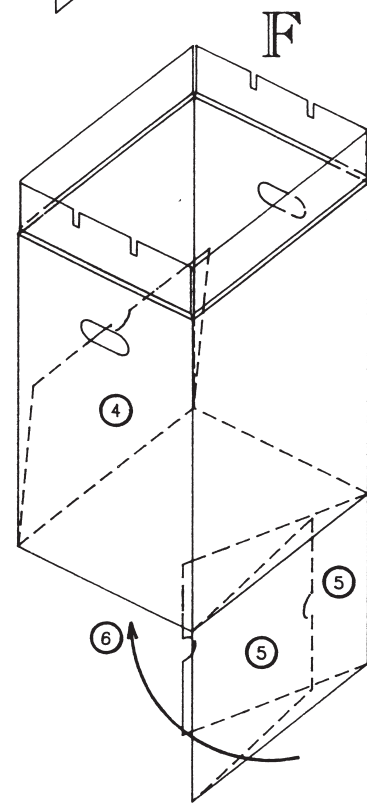
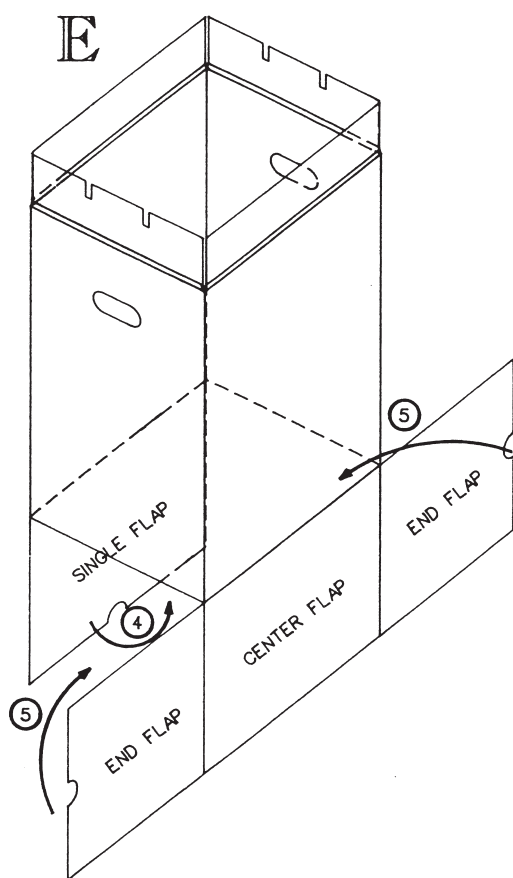

PARTITION

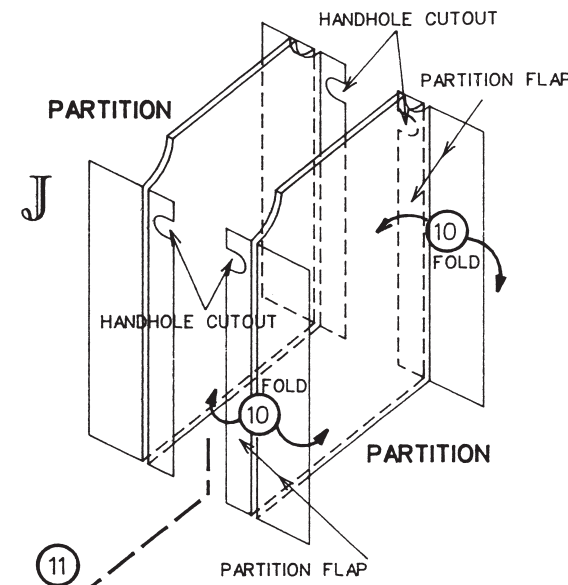

ASSEMBLED

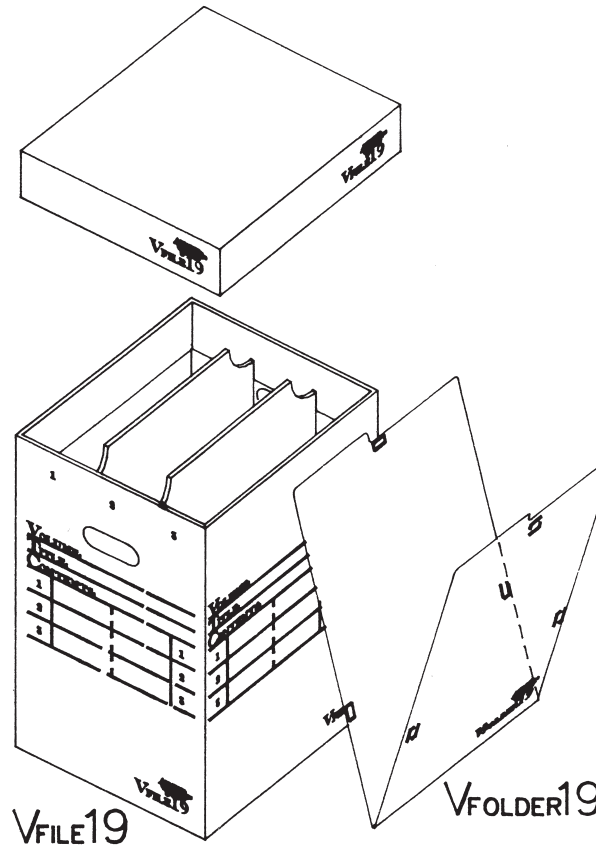

--PURCHASE SEPARATELY--
FOR USE WITH THE VFile19
AND THE VFile25

VFILE19

ADVANCED
ORGANIZING
SYSTEMS
Huntsville, Alabama

VFILE19

NOTE:

PRE-FOLD ALL SCORED FLAPS FOR CLEAN EDGE
PRIOR TO FOLDING FOR FINAL ASSEMBLY.

VFILE19 TOP (A through D)

- ① FOLD CORNER FLAPS OF THE SHORT SIDES UP. FOLD SHORT SIDES UP.
- ② WITH THE CORNER FLAPS OF THE LONG SIDES POINTING OUT, FOLD THE LONG SIDES OVER THE CORNER FLAPS OF THE SHORT SIDES. THIS WILL ALLOW THE CORNER FLAPS OF THE LONG SIDE TO LAY AGAINST THE SHORT SIDE.
- ③ FOLD IN SHORT SIDES & LOCK IN SLOTS.

VFILE19 BOX (E through G)

- ④ FOLD SINGLE FLAP IN AND AGAINST SIDE OF BOX INTERIOR.
- ⑤ FOLD END FLAPS FLAT AGAINST CENTER FLAP.
- ⑥ FOLD CENTER AND END FLAPS FLUSH WITH BOTTOM OF BOX & SET UPRIGHT.
- ⑦ USING FINGER HOLES, PULL END FLAPS IN & AGAINST SIDES OF BOX INTERIOR.
- ⑧ FOLD SINGLE FLAP TO BOTTOM OF BOX.
- ⑨ FLAPS REMAINS UPRIGHT PRIOR TO INSERTING PARTITIONS.

VFOLDER19 PARTITION (J)

- ⑩ WITH PARTITIONS FOLDED IN HALF ALONG THE SCORE (WHITE SIDE OUT), FOLD PARTITION FLAPS OUT.
- ⑪ INSERT EACH PARTITION IN BOX ALIGNING CUTOUTS WITH HANDHOLES.

VFILE19 BOX (H)

- ⑫ FOLD IN LONG SIDE FLAP.
- ⑬ FOLD IN SHORT SIDE FLAP LOCKING PARTITIONS IN SLOTS.