

INSTRUCTIONS

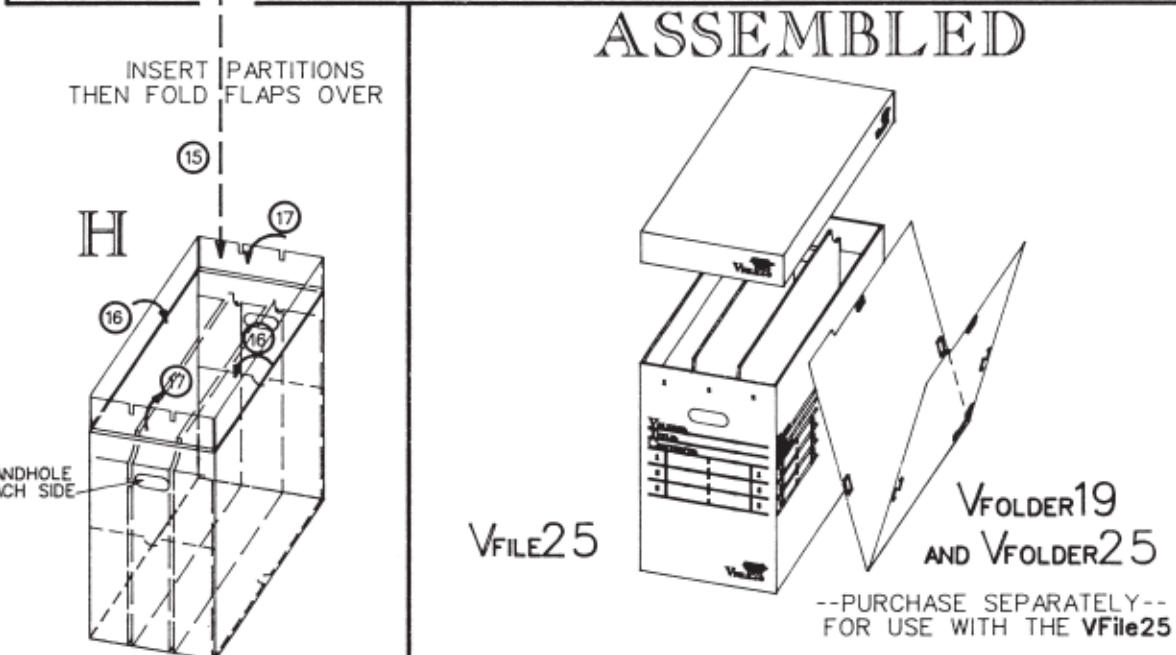
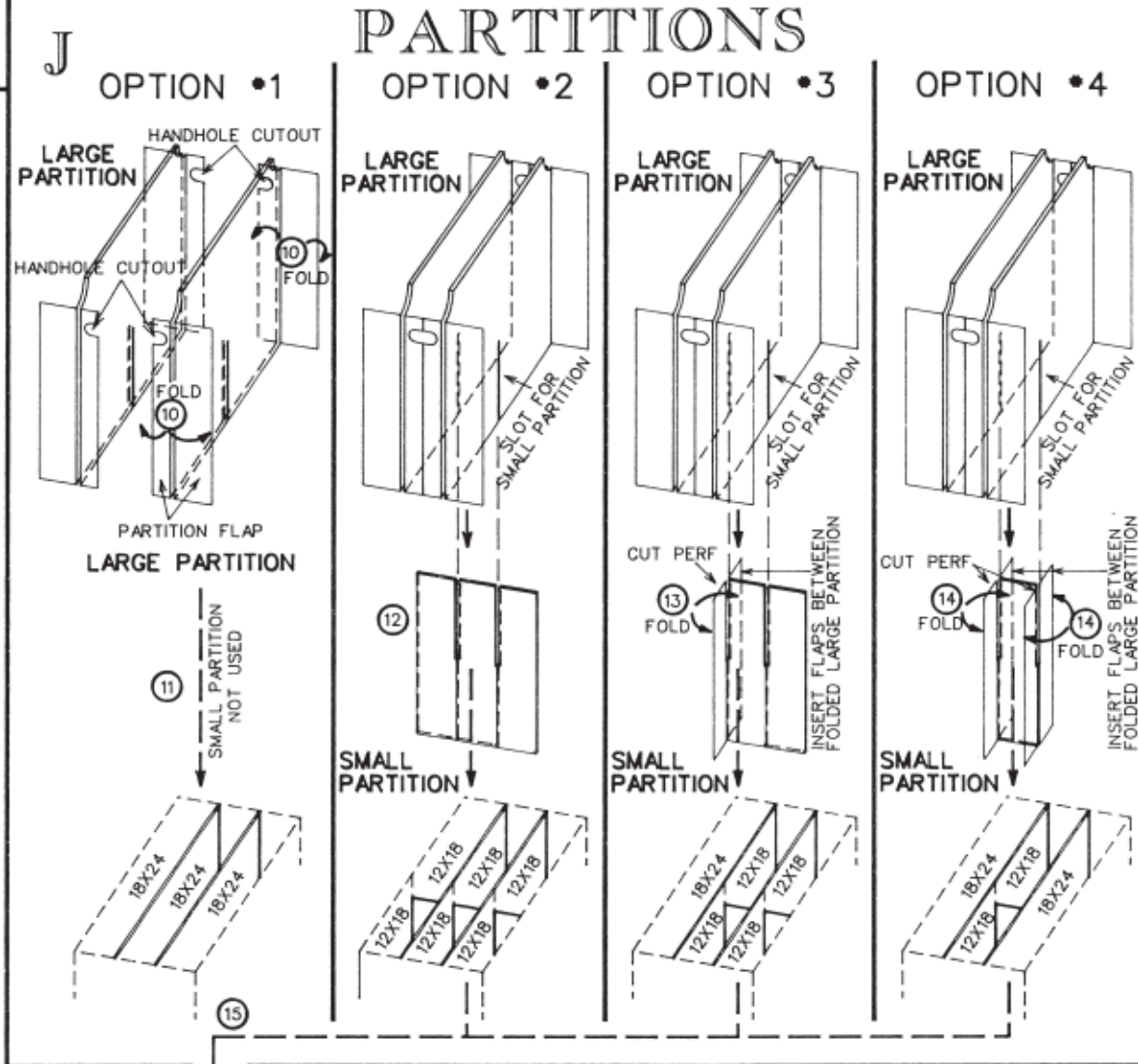
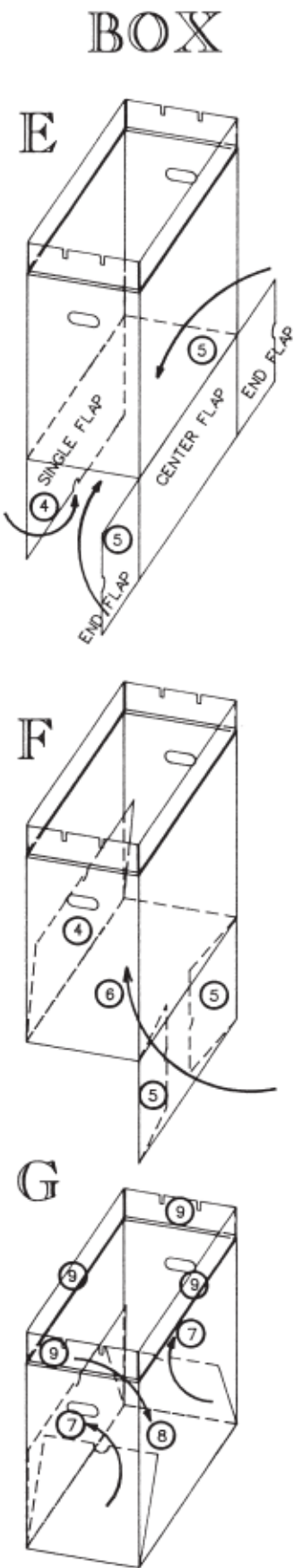
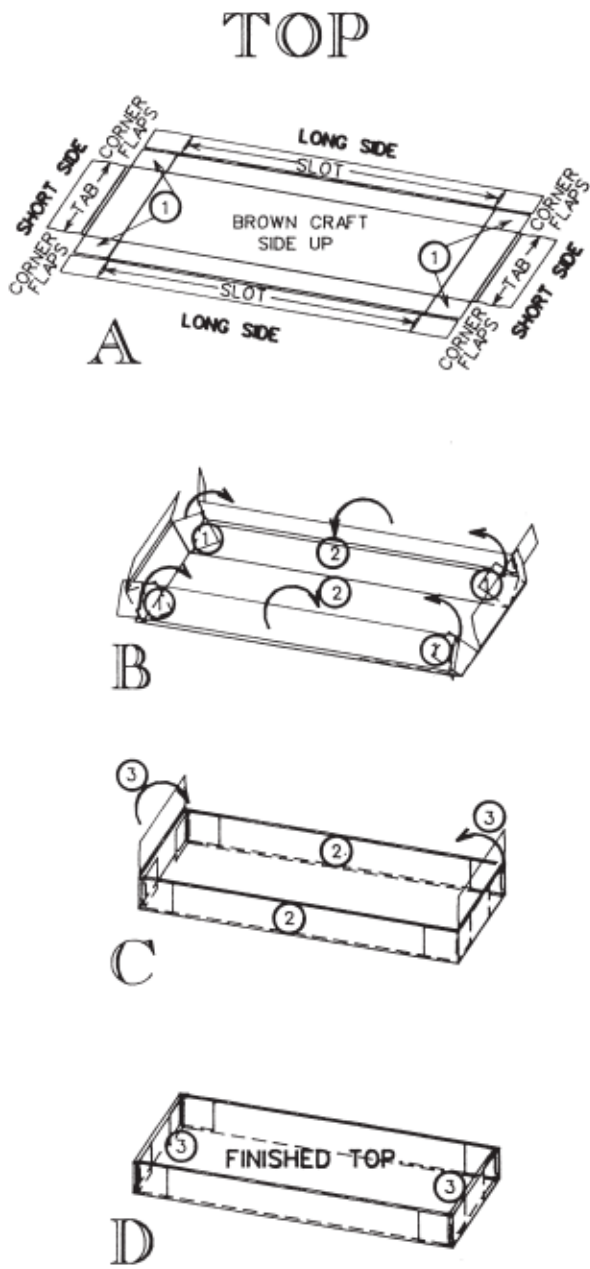

VFILE25

NOTE:
PRE-FOLD ALL SCORED FLAPS FOR CLEAN EDGE PRIOR TO FOLDING FOR FINAL ASSEMBLY.

VFILE25 TOP (A through D)

- 1 FOLD CORNER FLAPS OF THE SHORT SIDES UP. FOLD SHORT SIDES UP.
- 2 WITH THE CORNER FLAPS OF THE LONG SIDES POINTING OUT, FOLD THE LONG SIDES OVER THE CORNER FLAPS OF THE SHORT SIDES. THIS WILL ALLOW THE CORNER FLAPS OF THE LONG SIDE TO LAY AGAINST THE SHORT SIDE.
- 3 FOLD IN SHORT SIDES & LOCK IN SLOTS.

VFILE25 BOX (E through G)

- 4 FOLD SINGLE FLAP IN AND AGAINST SIDE OF BOX INTERIOR.
- 5 FOLD END FLAPS AGAINST CENTER FLAP.
- 6 FOLD CENTER AND END FLAPS FLUSH WITH BOTTOM OF BOX & SET UPRIGHT.
- 7 USING FINGER HOLES, PULL END FLAPS IN & AGAINST SIDES OF BOX INTERIOR.
- 8 FOLD SINGLE FLAP TO BOTTOM OF BOX.
- 9 FLAPS REMAIN UPRIGHT PRIOR TO INSERTING PARTITIONS.

VFolder25 PARTITION (J)

- 10 WITH PARTITIONS FOLDED IN HALF ALONG THE SCORE (WHITE SIDE OUT), FOLD PARTITION FLAPS OUT.
- 11 **OPTION 1** --3 LARGE SECTIONS-- OMIT SMALL PARTITION.
- 12 **OPTION 2** --6 SMALL SECTIONS-- JOIN 2 LARGE PARTITIONS WITH THE SMALL PARTITION AT PRE-CUT SLOTS.
- 13 **OPTION 3** --1 LARGE SECTION/ 4 SMALL SECTIONS-- WITH THE SMALL PARTITION FOLDED IN HALF ALONG THE PERFORATION (WHITE SIDE OUT), CUT PERFORATION ON ONE END & FOLD FLAPS OUT. POSITION THE FOLDED FLAPS OF THE SMALL PARTITION INSIDE ONE OF THE LARGE PARTITIONS. JOIN THE 2 LARGE PARTITIONS WITH THE SMALL PARTITION AT PRE-CUT SLOTS.
- 14 **OPTION 4** --2 LARGE SECTIONS/ 2 SMALL SECTIONS-- SIMILAR TO OPTION 3--REPEAT STEPS FOR BOTH ENDS OF SMALL PARTITION
- 15 INSERT IN THE BOX ALIGNING THE HANDHOLES.

VFILE25 BOX (H)

- 16 FOLD IN LONG SIDE FLAP.
- 17 FOLD IN SHORT SIDE FLAP LOCKING PARTITIONS IN SLOTS.

ADVANCED ORGANIZING SYSTEMS, INC.
www.aosystems.com

